

Bituthene® 4000

Self-adhesive HDPE waterproofing membrane with enhanced bonding characteristics for use with B2 moisture tolerant primer.

Advantages

- Cold applied - simple application to substrates especially at low temperatures.
- Suitable for application to “green” concrete - reduces programme schedules
- Moisture tolerant primer system - allows application in damp or marginal weather conditions.
- Wide application temperature range - excellent bond to self and substrate from -10°C to +35°C.
- Overlap security - enhanced-bond provides additional security.
- Cross laminated high density polyethylene carrier film - provides high tear strength, puncture and impact resistance.
- Flexible - accommodates concrete shrinkage cracks.
- Gas resistant - methane, carbon dioxide and radon gas protection in excess of the standard membrane requirements in BRE Reports 211 (radon) and 212 (methane and carbon dioxide).

Description

Bituthene® 4000 is a flexible preformed waterproof membrane combining a high performance cross laminated, HDPE carrier film with a unique super sticky self-adhesive rubber bitumen compound.

Ancillary Products

Primer B2

Primer B2 is used to prepare vertical and sloping surfaces and suspended slabs. It is moisture tolerant and can be used on “green” concrete or damp to touch substrates.

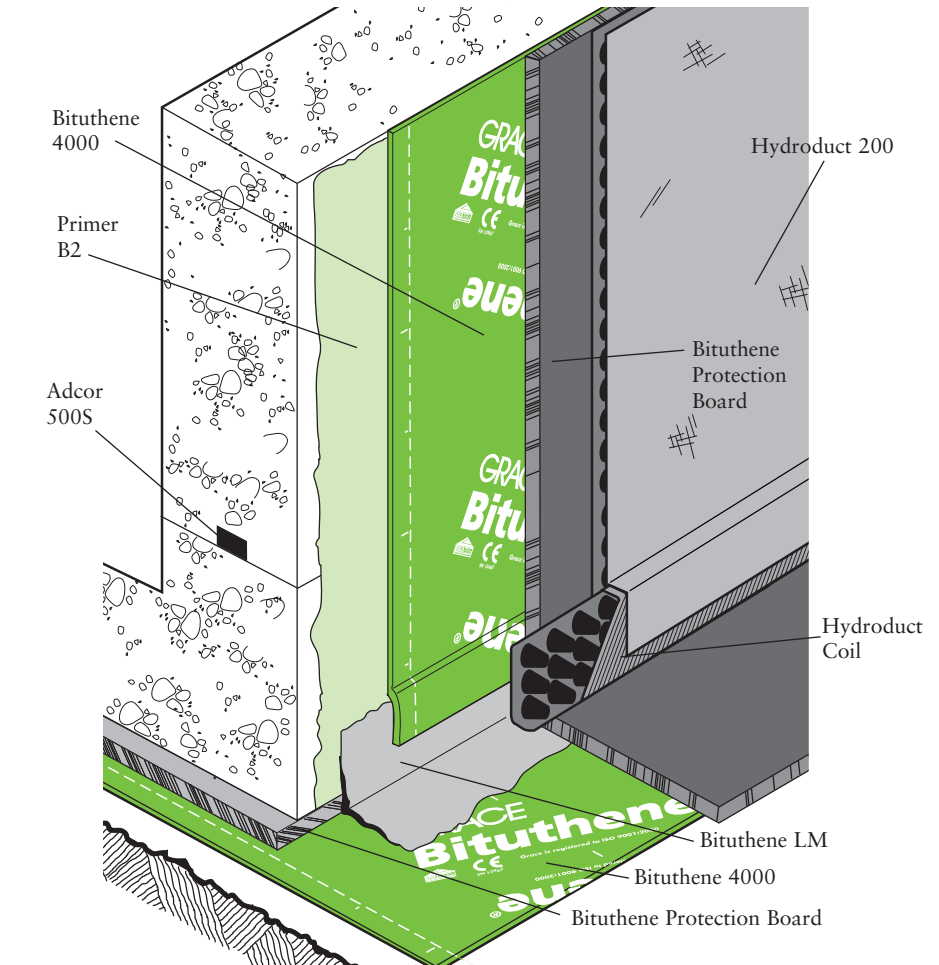

Bituthene® LM

Waterproof continuity at angles and at penetrations is provided by Bituthene LM two component chemically curing liquid applied waterproof membrane.

Bituthene® Protection Boards

Damage from following trades and backfill is prevented by Bituthene® Protection Boards. Located with Bitustik™ 4000 double sided tape.

Details shown are typical illustrations only and not working drawings. For assistance with working drawings and additional technical advice please contact Grace Technical Services

Supply

Bituthene® 4000	1 m x 20 m roll (20 sq m) Weight 32 kg
Palletisation	15 rolls per pallet
Storage	Store upright in dry conditions below +30°C
Primer B2	5, 25 litre drums
Coverage	10 - 12 sq m per litre depending upon method of application, surface porosity and ambient temperature
Ancillary Products	
Bituthene® LM	5.7 litre packs
Bituthene®	3 mm x 1 m x 2 m
Protection Boards	
Adcor® 500S	6 x 5 m rolls
Hydroduct®	In lieu of drainage stone
Waterstops	See separate data sheet for details
Bitustik™ 4000	150 mm x 12 m roll
Lap Roller	Unit

Installation

At air temperatures below +4°C measures should be taken to ensure that all surfaces are free from ice or frost. All surfaces except those below ground bearing slabs and Preprufe® R membranes should be primed with one coat of Primer B2 applied at a rate of approx. 10m² per litre.

Bituthene 4000 shall be laid by peeling back the protective release paper and applying the adhesive face onto the prepared surface, free from ice, frost, condensation or any contaminants which could adversely effect adhesion.

Bituthene LM to be applied at all internal and external corners, penetrations etc. prior to applying the overall membrane.

Bituthene 4000 should be brushed onto the surface to ensure good initial bond and exclude air. Adjacent rolls are aligned and overlapped 50mm minimum at side and ends and well rolled with a firm pressure, using a lap roller to ensure complete adhesion and continuity between the layers. On high walls it may be necessary to batten fix the membrane to prevent slippage.

Repairs

Damaged areas to be repaired by patching with an oversize patch applied to a clean dry surface and firmly rolled.

Performance

Bituthene 4000 complies with the relevant section of the following national standards:

BS 8102:1990, Building Regulations (England and

Physical Properties

Property	Typical Results	Test Method
Elongation at max load	Long 244% Trans 185%	BS 2782 320 A
Tear Resistance	Long 77N Trans 92N	MOAT 27:5.4.1
Peel Strength	76.5 N/mm ²	MOAT 27:5.1.3
Tensile Strength of joints	117N	MOAT 27:5.2.2
Moisture Vapour Permeability	0.31 g/m ² /24 hours	BS 3177: 1959 (75% RH/25°C)
Puncture Resistance	220 N 65mm	ASTM E154
Water Resistance (6m head)	No penetration	MOAT 27:5.1.4
Environmental Resistance	Conforms	ASTM D543

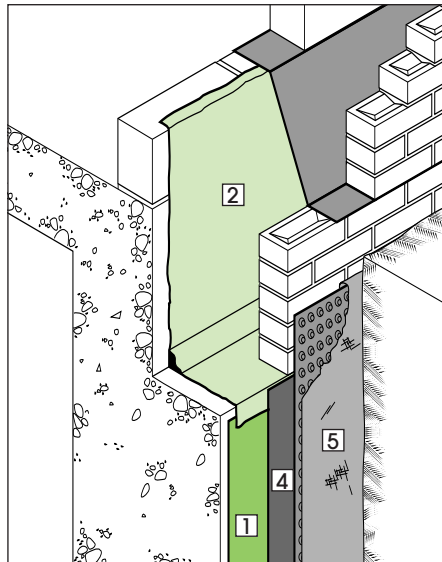

Typical ground level termination detail

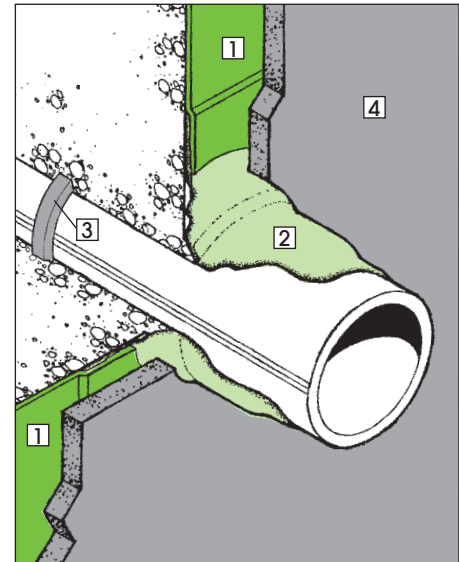

Pipe through wall detail

Key to diagrams:

- 1 Bituthene 4000 on Primer B2
- 2 Bituthene LM
- 3 Adcor 500S
- 4 Bituthene Protection Board
- 5 Hydroduct 220

Wales) 1991 (amended 1994) clause C4. Building Regulations (Northern Ireland) 1994 (amended 1995) clause B2. Building Standard (Scotland) Regulations 1990, Regulation B2.1, G2.6.

Health and Safety

There is no legal requirement for a Material Safety Data Sheet for Bituthene 4000, Bituthene Protection Boards, Bitustik, Lap Roller, Hydroduct or waterstops. For health and safety questions on these products please contact Grace Construction Products Limited.

For Primer B2, and Bituthene LM read the product label and Material Safety Data Sheet (MSDS) before use. Users must comply with all risk and safety phrases. MSDS's can be obtained from Grace Construction Products or from our web site at www.graceconstruction.com.

NBS Specification Clause

Refer to Clause 180 and 190.

web Visit our web site at www.graceconstruction.com

Grace Construction Products Ltd, Ajax Avenue, Slough, Berkshire SL1 4BH United Kingdom Tel +44 (0)1753 692929 Fax +44 (0)1753 691623

Adcor, Aerofil, BETEC, Bituthene, Hydroduct, Insupak, Korkpak, Paraflex, Paraseal, Preprufe, Procor, Serviseal, Servidek, Servigard, Servijoint, Servimastic, Servipak, Servirufe, Serviseal, Servistrip, Servitite, Vertigard and Vertiseal are registered trademarks of W R Grace & Co.-Conn.
Adprufe, Armourtape, Bitushield, Bitustik, Bitutape, Hydropaste, Pak Adhesive, PVC Edgetie, Serviband, Serviflex, Servitape, Slipstrip, and Solarshield are trademarks of W R Grace & Co.-Conn.

The information given is based on data and knowledge considered to be true and accurate and is offered for the user's consideration, investigation and verification. Since the conditions of use are beyond our control we do not warrant the results to be obtained. Please read all statements, recommendations or suggestions in conjunction with our conditions of sale including those limiting warranties and remedies which apply to all goods supplied by us. No statement, recommendation or suggestion is intended for any use which would violate or infringe statutory obligations or any rights belonging to a third party.

Copyright 2006. Grace Construction Products Limited.

Printed in England - 05.06- Ref. WM004C

GRACE
Construction Products